

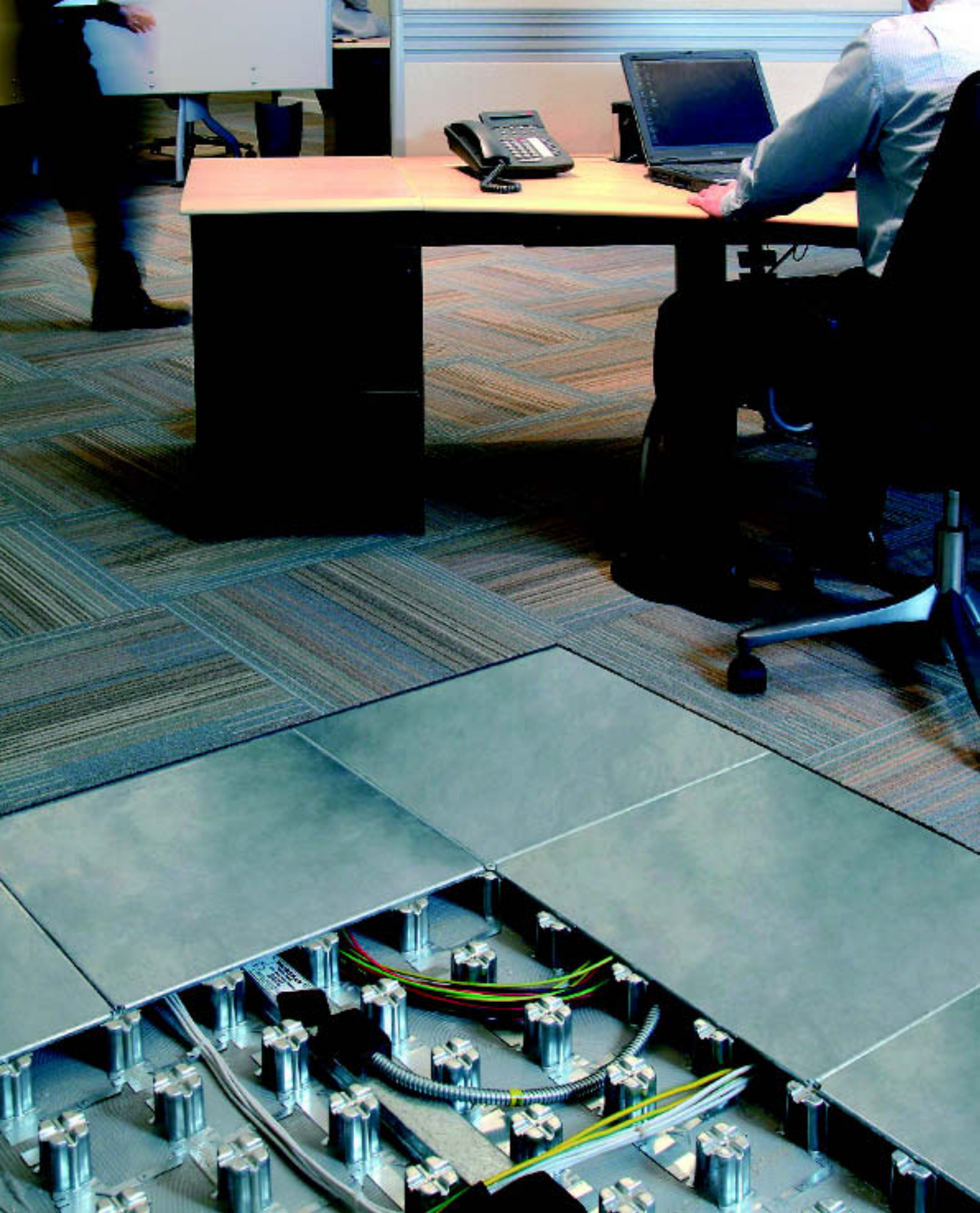

The Intercell cable management flooring system  
equips today's offices for tomorrow's needs

# Intercell

**cable management  
flooring system**



# Intercell office for life

Intercell is a trademark of Interface, the world's biggest manufacturer of modular flooring solutions. Interface believes in sustainable solutions changing costs into investments. The Intercell cable management system avoids unnecessary costs, since Intercell was designed by people who listened carefully to users of buildings and their constantly changing needs. Key requirement here was the ease of workspace change, which was easily met by Intercell with its full flexibility. Flexibility in use. Flexibility in application. Flexibility in design.

With Intercell we are ready for your future!

## features and benefits

Intercell - the low profile Cable Management Flooring System from Interface offers a strong, space saving cellular flooring system, designed to manage cable distribution in existing and new structures. The Intercell floor offers a complete package of practical and long-term benefits:

### Easy handling and installation

With its practical modular size of 500 x 500 mm., Intercell offers easy handling, transport, storage and of course installation.

### Building site efficiency

The practical installation of Intercell offers site-efficiency, small areas can be handed over quicker resulting in a shorter programme and less disruption.

### Cable installation

Installation of cabling is much easier and faster compared with ceiling, wall and cableducting systems. A special Intercell floorbox offers full compatibility to most standard European connector types.

### Cable capacity

Despite the low height of the system, Intercell offers maximum cabling-capacity. The multi-pedestal structure creates a basis for natural cable distribution and separation.

### Low height

With its low profile, Intercell offers minimal floor-to-ceiling encroachment and can be installed in existing or new buildings with little or no loss of headroom, saving substantial construction costs.

### High performance

With 16 pedestals per panel and 64

pedestals per m<sup>2</sup> Intercell creates a solid and safe underfoot feel. The load carrying capacity is outstanding.

### Low weight

The additional weight to the building structure is 22 kg/m<sup>2</sup> at a maximum.

### Static dissipation

Intercell does not adversely affect the modular carpet static propensity and static dissipation properties.

### No settlement adjustments

Once installed, Intercell will not require any settlement adjustments or de-rocking, which saves operational costs and minimises workspace disruption.

### Future planning advantages

Intercell has enough cable capacity to suit any future needs and is easy to reconfigure when organisations need to change, resulting in lower operational costs of the building.

# overview of Intercell components

- 01 Pedestal panel (50 x 50 cm)
- 02 Steel plate (50 x 50 cm)
- 03 Megascrew
- 04 Edge rail
- 05 Ramp
- 06 Acoustical firebarrier

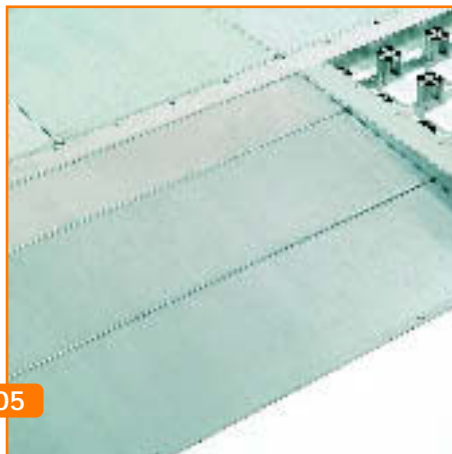
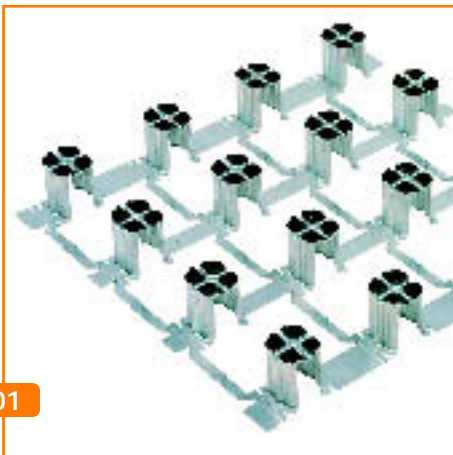

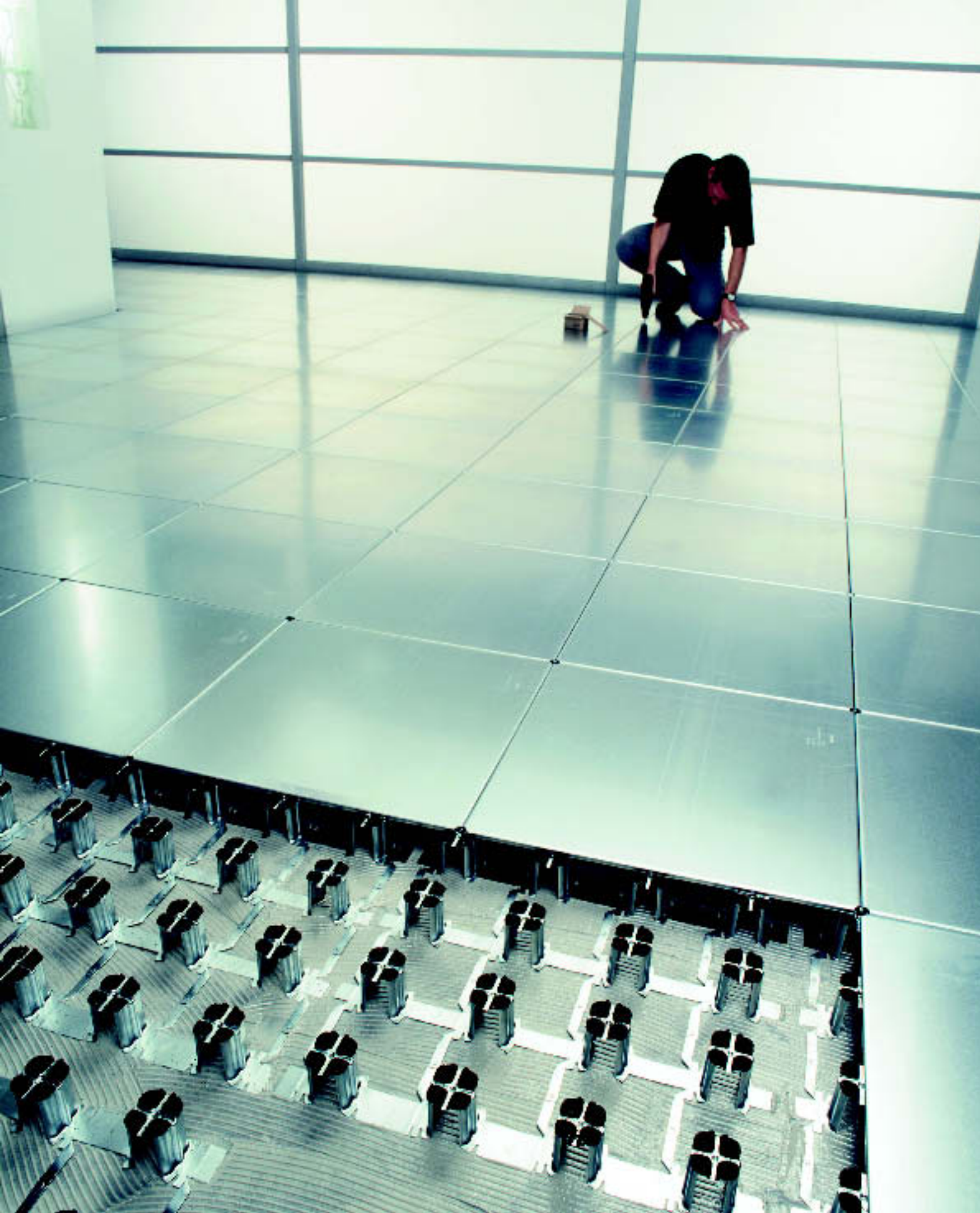

# testresults

Subject	Description	Testresults
Pointload 25 x 25 mm.	This test simulates the effect of a pointload.	Maximum deflection: * at 3000 N < 2,4 mm Maximum permanent indentation: * at 3000 N < 0,8 mm
Maximum working load.	This test simulates the maximum workingload on a point loading of 25 x 25 mm.	Maximum working load = 10 kN.
Uniformly distributed load.	This test simulates an uniform load for a period of 24 hours.	Deflection at 16000 N/m2: < 0,5 mm. Deflection at 48000 N/m2: < 0,5 mm.
Soft Body Impact test.	A 40 kg soft body is dropped onto the system from a height of 1 mtr.	The system did not collapse.
Hard Body Impact test.	A 4,5 kg hard body is dropped onto the system from a height of 60 cm.	The system did not collapse.
Surface spread of flame.	This test uses the radiant panel according to BS 476.	Class 1: 0,00 mm spread of flame.
Small Scale Fire test.	A fire is created in the void with 1 kg of wood which is allowed to burn for 30 minutes. The whole system is loaded with 800 kg/m2.	Maximum deflection: 0,98 mm.
Fire test for building products acc DIN 4102.	Determination of inflammability and contribution to the extension of the fire.	Class B1.
EMC test: Electro Magnetic Compatibility.	Protection of the system regarding electromagnetism.	Attenuation: * from 3 - 30 Mhz: approx. 25 dB * from 30 - 1000 Mhz: approx. 20 dB
Vertical impact sound isolation: ISO 717/2.	The impact sound isolation is measured from a room above to a room downstairs.	Delta Lw: * without carpet: 23 dB * with carpet: 30 dB
Horizontal impact sound isolation: ISO 717/2.	The impact sound isolation is measured from one room to a room annex using 2 rockwool barriers.	L n, f, w = 46 dB.
Vertical airborne sound isolation: ISO 717/1.	The airborne sound isolation is measured from one room to a room downstairs.	Delta Rw: * without carpet: 52 dB * with carpet: 57 dB
Horizontal airborne sound isolation: ISO 717/1.	The airborne sound isolation is measured from one room to a room annex using two rows of rockwool.	D n, f, w = 53 dB.
Thermal isolation value: ISO 10211-1.	The thermal dissipation is measured in m2 K/W.	Rc-value (58mm system): * without carpet: 0,083 m2 K/W * with carpet: 0,153 m2 K/W

**Warranty:** Interface Europe warrants the Intercell product to perform to the specifications published here above and in the full performance document in accordance with the terms stated in the warranty document available from your local Interface office. Copies of specific testreports are available on request.

# pedestal panels

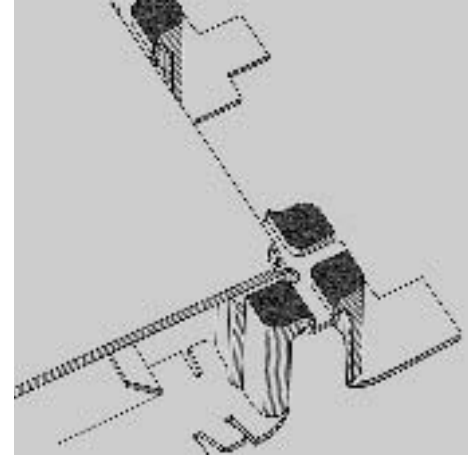
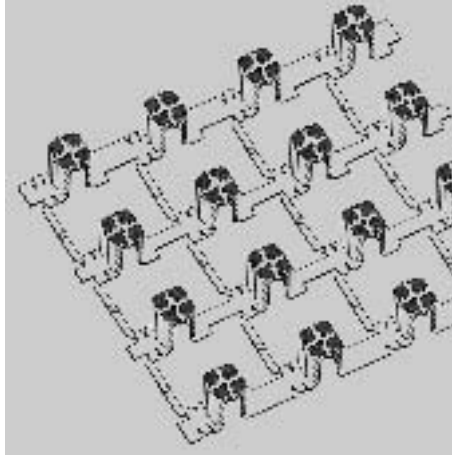

The modular pedestal panels of the Intercell system are made of galvanised steel with a heart to heart distance between the pedestals of 125 mm. The pedestals with heights of 38, 58, 88 or 108 mm have a locating channel on the top of each pedestal to align and secure the top plates. To reduce impact sounds, a recycled rubber has been applied to the top of the pedestals. The pedestals, forming a natural cable way, are bonded to the subfloor using a special Intercell adhesive that allows an easy and clean installation without any drilling.

## TECHNICAL DETAILS

Pedestal panel	Height 58 mm	Height 88 mm	Height 38 mm	Height 108 mm
Style code	71167	71267	71367 (optional)	71467 (optional)
Material	galvanised steel	galvanised steel	galvanised steel	galvanised steel
Sounddeadening material	recycled rubber	recycled rubber	recycled rubber	recycled rubber
Colour	grey	grey	grey	grey
Supp. pedestals per/m <sup>2</sup>	64	64	64	64
Weight kgs/m <sup>2</sup>	4,0 kg	5,2 kg	3,2 k	6,0 kg
Dimensions	495 x 425 mm	495 x 425 mm	495 x 425 mm	495 x 425 mm
Pedestal units per box	20 (5 m <sup>2</sup> )	20 (5 m <sup>2</sup> )	28 (7 m <sup>2</sup> )	16 (4 m <sup>2</sup> )
Panels per m <sup>2</sup>	4	4	4	4

# steel plates

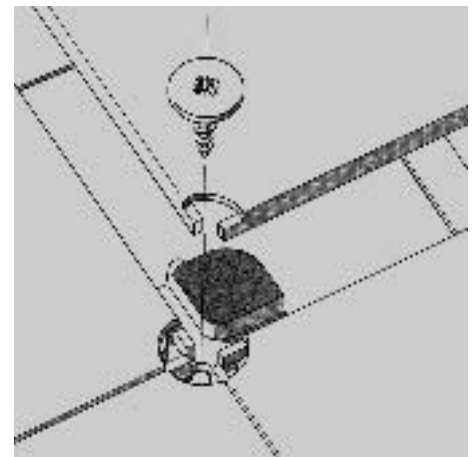
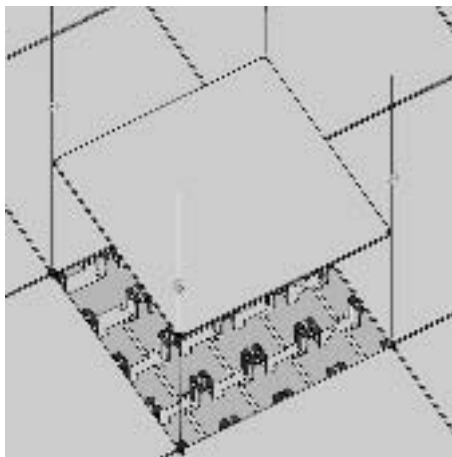
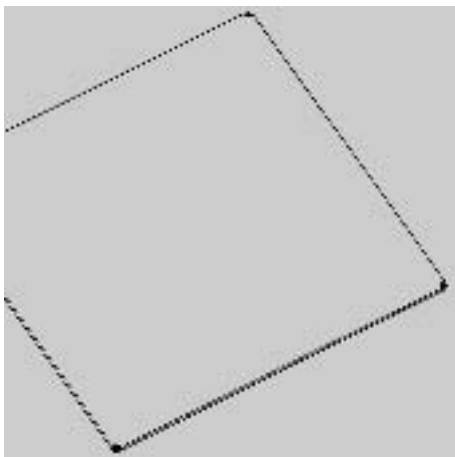

The top plates of the Intercell system have a dimension of 500 x 500 mm and are made of hot dipped galvanised steel. The edges of the plates are folded at 90° holding the plates in position when installed on top of the pedestal modules. Each corner of the steelplate has holding edges for fixing the screw. The specially designed screw has a washer that overlaps the holding edges of the steelplate corner.

## TECHNICAL DETAILS

	Steelplate	Megascrew (screw/washer incorp.)
Stylecode	71073	71013
Material	galvanised steel	galvanised steel
Weight kg/m <sup>2</sup>	16	
Dimensions	500 x 500 mm	4,8 x 19 mm x 15,5 mm (washer)
Plates per box	80 pieces (20 m <sup>2</sup> )	
Plates per m <sup>2</sup>	4	
Screws per box	200 pcs.	

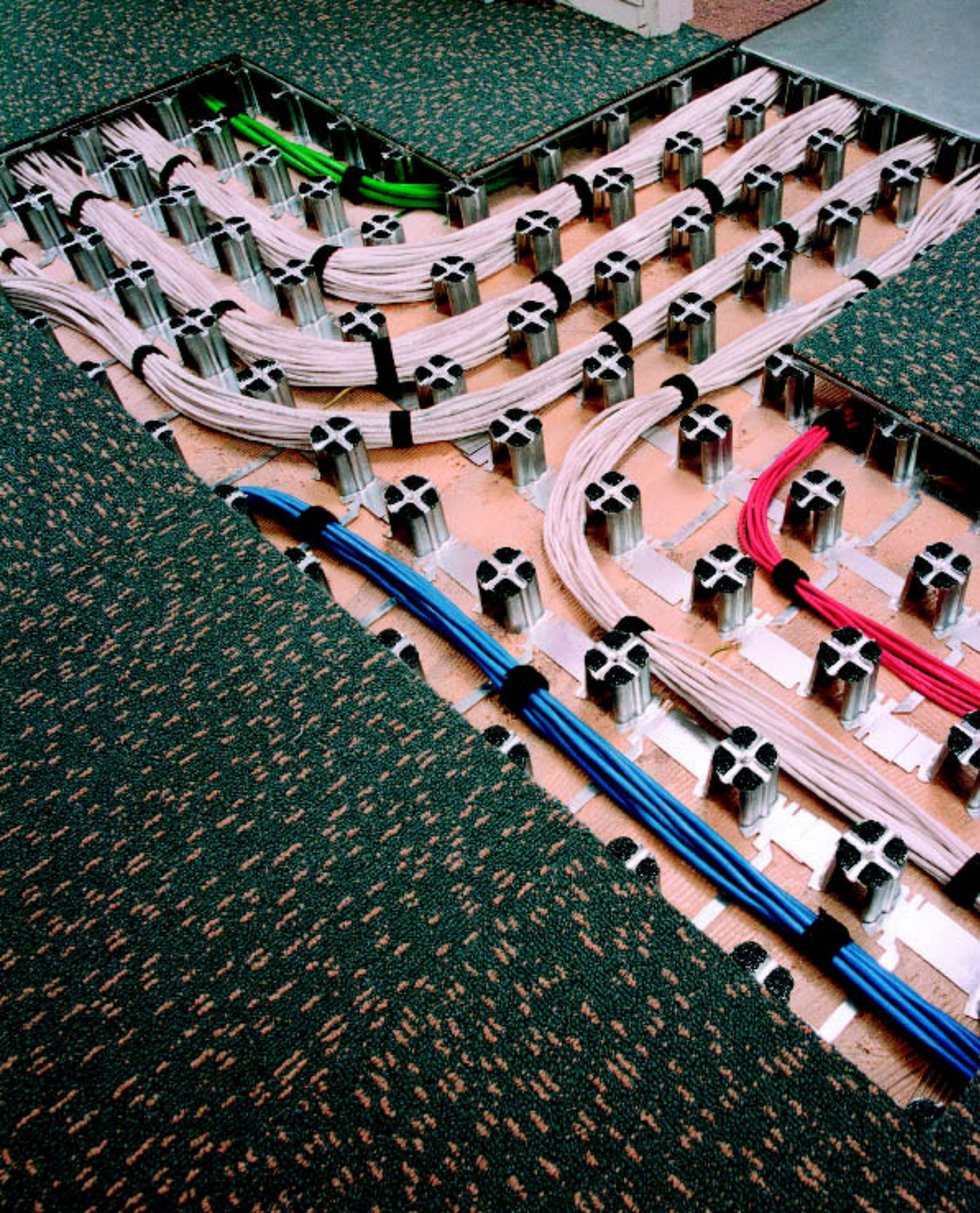



# edge rails

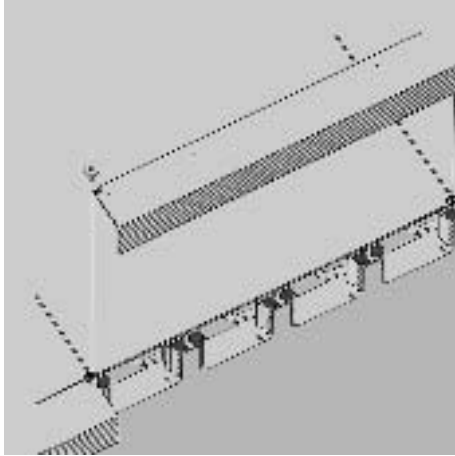

The edge rail is designed to lock into the pedestal keyway and provides a finished edge where the flooring system does not end at a wall or partition.

## TECHNICAL DETAILS

Edge rails	60 mm system	90 mm system	40 mm system	110 mm system
Stylecode	71117	71217	71317	71417
Material	galvanised steel	galvanised steel	galvanised steel	galvanised steel
Weight	3,8 kg	4,8 kg	3,2 kg	5,4 kg
Length dimensions	2000 mm	2000 mm	2000 mm	2000 mm
Width dimensions	65 mm	65 mm	65 mm	65 mm
Height dimensions	60 mm	90 mm	40 mm	110 mm

# acoustical barriers

The acoustical firebarriers are made of high density, non-flammable stonewool and wrapped in polyethylene foil. They fit exactly in between two pedestal rows of the pedestal module. The barrier is used to reduce sound travel under the floor, especially in installations where separation walls are placed over the flooring system. The barrier is also used as a firebreak.

## TECHNICAL DETAILS

Acoustic barriers	60 mm system	90 mm system	40 mm system	110 mm system
Stylecode	71632	71633	71653	71658
Material	stone wool	stone wool	stone wool	stone wool
Weight	850 gr	1300 gr	560 gr	1550 gr
Height dimensions	57 mm	87 mm	37 mm	107 mm
Length dimensions	1200 mm	1200 mm	1200 mm	1200 mm
Width dimensions	80 mm	80 mm	80 mm	80 mm

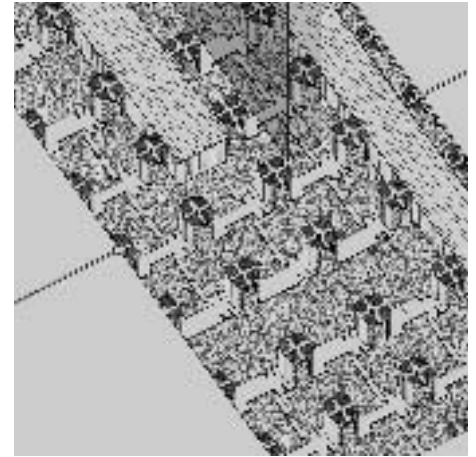

# ramps

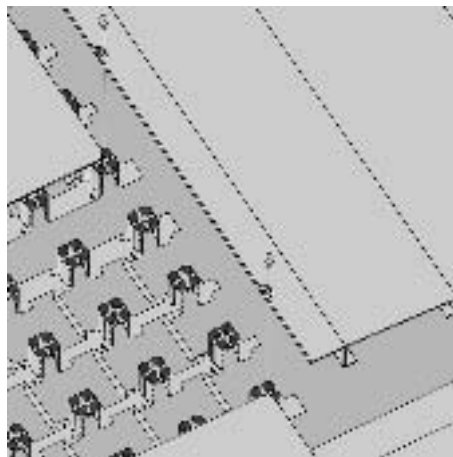
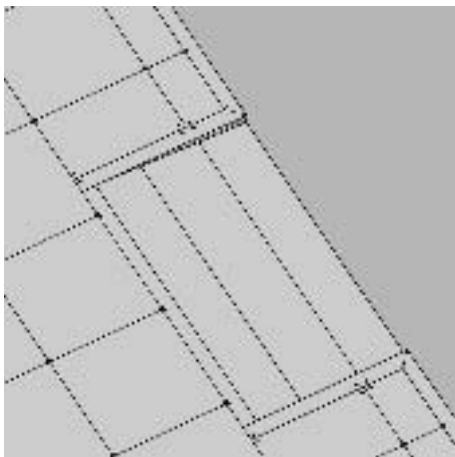

The sectional steel ramp is used to descend the Intercell system. The standard gradient is 5°. The ramp comes in 2, 3, 4 or 5 parts depending on the height of the system. To install a ramp into an Intercell floor, additional edge rails are needed around the ramp.

## TECHNICAL DETAILS

Ramps	60 mm system	90 mm system	40 mm system	110 mm system
Stylecode	71142	71242	71342	71343
Material	galvanised steel	galvanised steel	galvanised steel	galvanised steel
Colour	grey	grey	grey	grey
Weight	20,1 kg	31,5 kg	12,5 kg	41,1 kg
Length dimensions	670 mm	1020 mm	440 mm	1247 mm
Width dimensions	1000 mm	1000 mm	1000 mm	1000 mm
Nr. of parts	3	4	2	5
Gradient	5°	5°	5°	5°



# Intercell woodfloor

Modern technology under a classical floorcovering. The Intercell woodfloor combines the advantages of a flexible cable

management flooring system with the ambiance of warm and beautiful

woodspecies like oak, ash and merbau. Just as easy to install and

to use as the same floor using modular floorcovering from Interface.

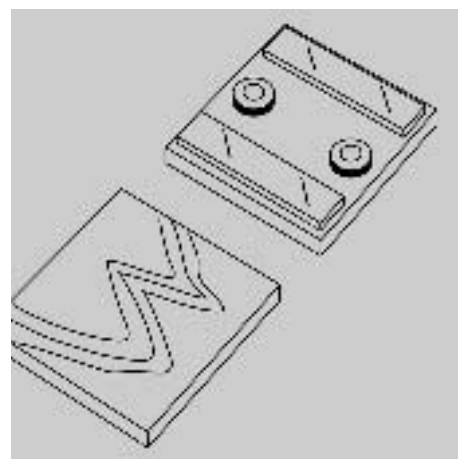
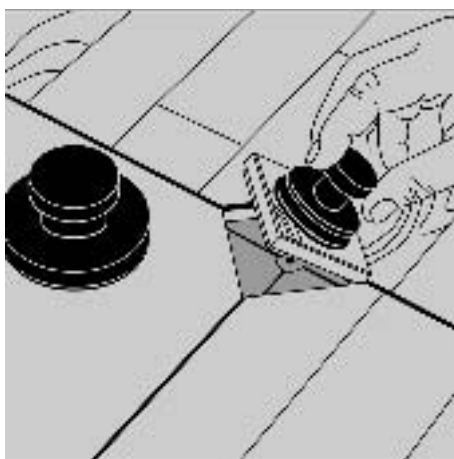
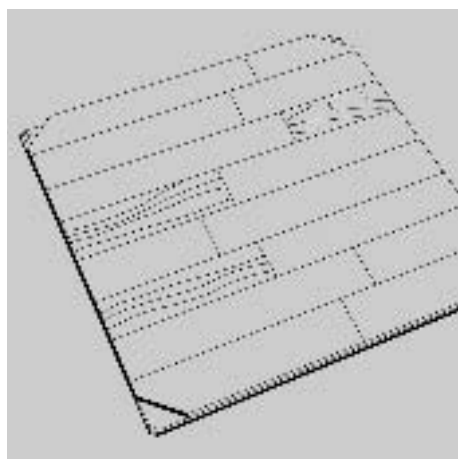

The Intercell woodfloor product combines 2 in 1: the Intercell cable management system and a high quality parquet woodfloor, all installed in one go! This product consists of a 14 mm woodfloor and a 3,6 mm thick surface layer in oak, ash or merbau glued to the top of an Intercell steelplate. The corners are cut off diagonally leaving space for the megascrew to be used. The remaining open square (67 x 67mm) when 4 plates have been installed can be covered with a so called corner lock that has 2 magnets at the back to attach them to the steel and keep them safely positioned.

## TECHNICAL DETAILS

Intercell woodfloor	Oak	Ash	Merbau
Style code	71101	71103	71105
Material	galv. steel + oak	galv. steel + ash	galv. steel + merbau
Total thickness	14 mm	14 mm	14 mm
Total weight (incl. corner locks)	24 kg/m <sup>2</sup>	24 kg/m <sup>2</sup>	24 kg/m <sup>2</sup>
Total wearlayer	3,6 mm	3,6 mm	3,6 mm
Taber test	7000 turns	7000 turns	7000 turns
Brinell hardness	3,7	4	5,5
Dimensions	500 x 500 mm	500 x 500 mm	500 x 500 mm
Dimensional stability	+0,02% /-0,04%	+0,02% /-0,04%	+0,02% /-0,04%
Panels per m <sup>2</sup>	4	4	4

## TECHNICAL DETAILS

Intercell cornerlocks	Oak	Ash	Merbau
Style code	71102	71104	71106
Material	oak squares with 2 magnets	ash squares with 2 magnets	merbau squares with 2 magnets
Total thickness	14 mm	14 mm	14 mm
Total wearlayer	3,6 mm	3,6 mm	3,6 mm
Taber test	7000 turns	7000 turns	7000 turns
Brinell hardness	3,7	4	5,5
Dimensions	67 x 67 mm	67 x 67 mm	67 x 67 mm
Squares per m <sup>2</sup>	4	4	4

**Asia Pacific**  
tel: +65 478 1510

**Australia**  
tel: +61 2 9698 3303

**Belarussia**  
tel: +375 17 / 226 7514

**Belgium**  
tel: +32 2 475 27 27

**Bulgaria**  
tel: +359 2 / 9 46 11 74

**Czech Republic**  
tel: +420 2 / 20 51 34 08

**Denmark**  
tel: +45 33 79 70 55

**France**  
tel: +33 1 58 10 20 20

**Germany**  
tel: +49 2151 / 3 / 18-0

**Hungary**  
tel: +36 1 / 3 84 90 05

**India**  
tel: +91 80 299 8568

**Ireland**  
tel: +353 1679 8466

**Italy**  
tel: +39 02 27 71 101

**Netherlands**  
tel: +31 33 277 5555

**Norway**  
tel: +47 22 59 07 20

**Poland**  
tel: +48 22 / 5 83 94 60

**Portugal**  
tel: +351 213 155 932

**Romania**  
tel: +40 1 / 3 35 43 24

**Russia**  
tel: +7 095 / 9 33 3881

**Slovenia**  
tel: +386 61 520 0518

**South Africa**  
tel: +27 16 366 1033

**Spain**  
tel: +34 93 241 87 50

**Sweden**  
tel: 020-790688

**Switzerland**  
tel: +41 1 / 9 13 68 00

**U.A.E.**  
tel: +9/1 43 368 //8

**Ukraine**  
tel: +380 44 / 461 9883

**United Kingdom**  
tel: +44 8705 304030

# Intercell

## cable management flooring system

**InterfaceFLOR bv**  
Industrielaan 15, P.O.Box 16  
3925 ZN Scherpenzeel  
The Netherlands  
tel +31 (0)33 277 55 55  
fax +31 (0)33 277 55 54  
[www.interfaceflor.eu](http://www.interfaceflor.eu)