

# FORTRESS

## PSA Medium Grade Gravity Lay Raised Flooring System

# 11



## Features

- PSA Medium Grade Raised Flooring System
- Bare Galvanised Steel Finish
- Designed to be overlaid with Carpet Tiles
- Suitable for Commercial Office Environments
- Unique Anti-Delamination Design

# FORTRESS PSA Medium Grade Raised Flooring System



Zinc Passivated Steel adjustable Understructure for heights from 60 mm to 1200 mm



## Panel Section

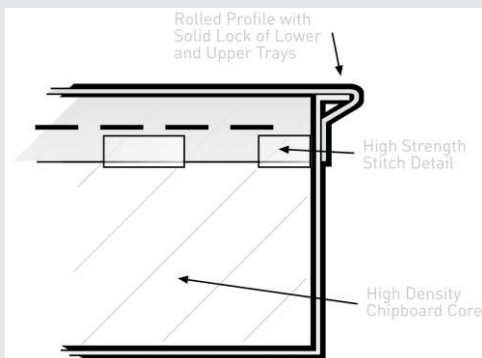

## Performance and Technical Specification

Size	600 mm x 600 mm
Thickness	31 mm (bare)
Weight	10.15 kg per panel
Point Load	3.0 kN
UDL	8.0 kN
Safety Factor	3
System Heights	60 mm to 1200 mm
Panel Coating	Galvanised Steel
Steel Thickness	0.5mm
Certified	PSA MOB Medium Grade BSEN 12825:2001 CLASS 5/A/3/1

## PRODUCT DESCRIPTION

The FORTRESS PSA MOB PF2 PS/SPU panel is a medium grade, gravity loose lay panel encapsulated in corrosion resistant galvanised steel, with a high density chipboard core, ideally suited to a wide range of applications, where strength and long life are the primary concerns.

## UNIQUE FOLDED DESIGN

The unique lid to tray locking system is further strengthened by the mechanical stitching. This is a unique feature that has been designed to give the panel exceptional strength and integrity. The panels have a galvanised steel bottom tray with a 4mm out turned profile. The steel lid is then rolled around the lower profile creating a locked, double layer of steel. This is then mechanically stitched delivering optimum strength and integrity from the panel.

## APPLICATION

Primarily designed to be installed in demanding modern office environments where access to the void is required. The system once installed delivers a safe working platform which can be overlaid with carpet tiling or a variety of finishes. Independently certified to the highest standard PSA MOB 08-801 PF2 PS SPU for Raised Access Flooring ensures low maintenance, durability and long life.

Design life of 25 years for Panels and 50 years for supporting understructure when used in accordance with Maintenance Instructions.

**The Access Flooring Company**  
Unit 4  
Norton House  
Fircroft Way Edenbridge  
Kent TN8 6EL

T: 0870 350 0415  
F: 0870 350 0425



[www.accessflooring.com](http://www.accessflooring.com)