

# Truespan

## PSA Medium Grade Raised Access Flooring

**T**ruespan Raised Access Flooring is independently certified to exceed MOB PF2 PS for Medium Grade Raised Access Flooring Systems.

- ◆ 600 x 600 x 31 mm galvanised steel encapsulated panel / design life 25 years
- ◆ High Density Particleboard Core
- ◆ MOB PF2 PS Medium Grade Certification
- ◆ Electro plated Steel adjustable Support Structure / design life 50 years
- ◆ Floor Heights from 50mm to 1000mm
- ◆ Unique anti-delamination design
- ◆ Manufactured in the UK

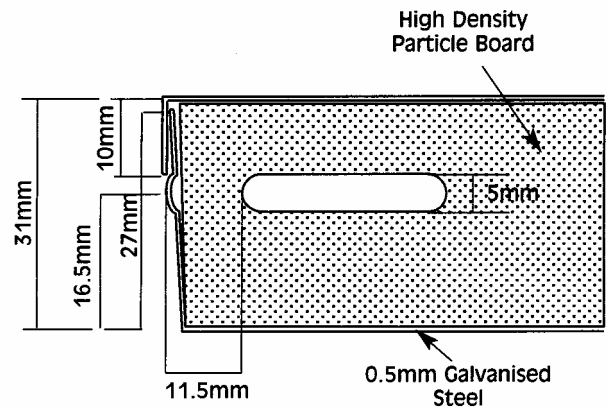

### System Description

The system comprises of an engineered nominal 600mm x 600mm x 31mm P6 high density particleboard panel encased in galvanised steel. The panel is gravity laid onto all steel electro-plated adjustable pedestals which are fixed to the sub-floor, either by epoxy resin or by a combination of epoxy resin and mechanical fixings. The pedestals are levelled using laser levels to achieve a flat and level surface. This produces a level working platform with an accessible 600 x 600 grid for finishing with carpet tiles suitable for general office use. Access to the void is achieved using a simple suction lifting device.

### Loading Capacity

Point load 25mm x 25mm	3.0kn
300mm x 300mm	4.5kn
Uniform Distributed Load	8.0kn

All values will withstand a safety factor of 3 before failure.

Where particularly heavy pieces of equipment need to be placed on the floor the loading of the system can be enhanced by the installation of additional pedestals.

### Application

A typical application for the Truespan System would be general office use, library rooms and schools that require the flexibility of a high performance access floor. The face of the floor panel would then normally be finished by the installation of a carpet tile on a tackifier.

### Ancillary Items

A complete range of electrical floorboxes, cable ports and grommets are available to complement the system.

### The Access Flooring Company

Unit 5 Hortons Way Westerham Kent TN16 1BT

Tel: 01959 567840 Fax: 01959 567845

email: [enquiries@accessflooring.com](mailto:enquiries@accessflooring.com)

[www.accessflooring.com](http://www.accessflooring.com)