

ULTRASPAN –Screwdown

PSA Medium Grade Raised Access Flooring

Ultraspan Raised Access Flooring is independently certified to exceed MOB PF2 PS for Medium Grade Raised Access Flooring Systems.

- ◆ 600 x 600 x 31 mm galvanised steel encapsulated panel / design life 25 years
- ◆ High Density Particleboard Core
- ◆ MOB PF2 PS Medium Grade Certification
- ◆ Electro plated Steel adjustable Support Structure / design life 50 years
- ◆ Floor Heights from 50mm to 1000mm
- ◆ Unique anti-delamination design
- ◆ Cornerlocking System
- ◆ Manufactured in the UK

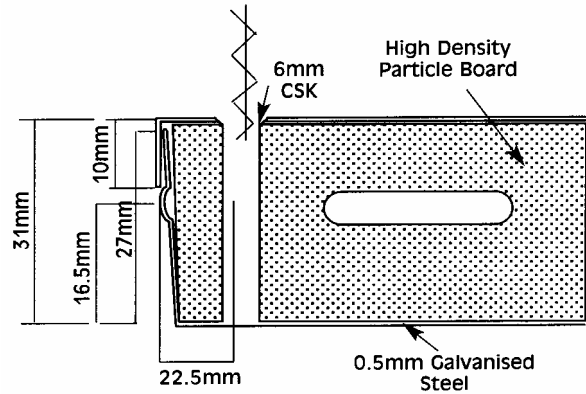

System Description

The system comprises of an engineered nominal 600mm x 600mm x 31mm P6 high density particleboard panel encased in galvanised steel. The panel is screw fixed using a taptite screw in each corner onto all steel electro-plated adjustable pedestals which are fixed to the sub-floor, either by epoxy resin or by a combination of epoxy resin and mechanical fixings. The pedestals are levelled using laser levels to achieve a flat and level surface. This produces a level working platform with an accessible 600 x 600 grid for finishing with carpet tiles suitable for general office use. Access to the void is achieved using a simple suction lifting device.

Loading Capacity

| | |
|--------------------------|-------|
| Point load 25mm x 25mm | 3.0kn |
| 300mm x 300mm | 4.5kn |
| Uniform Distributed Load | 8.0kn |

All values will withstand a minimum safety factor of 3 before failure.

Where particularly heavy pieces of equipment need to be placed on the floor the loading of the system can be enhanced by the installation of additional pedestals.

Application

A typical application for the ULTRASPAN System would be general office use, library rooms and schools that require the flexibility of a high performance access floor. The face of the floor panel would then normally be finished by the installation of a carpet tile on a tackifier.

Ancillary Items

A complete range of electrical floorboxes, cable ports and grommets are available to complement the system.

The Access Flooring Company

Unit 5 Hortons Way Westerham Kent TN16 1BT

Tel: 01959 567840 Fax: 01959 567845

email: enquiries@accessflooring.com

www.accessflooring.com