



DONN DSF2 - Solidfeel System Medium Grade Product Specification Guide

Features

- Support structures within each of 25 pockets plus 160 separate welds mean extra strength
- Full hard top sheet and advanced cementitious fill for added strength and suitability for fastrack programmes
- Steel die formed bottom pan with continuous drawn corners and I-beam edge construction
- Incombustible
- Humidity - tested per PF2 PS
- Heavy panels improve acoustic performance
- Silent floor with Panel-Loc system
- Improved performance to withstand rolling loads
- Quality assured manufacture - to ISO 9002
- Loose lay and screw down options available

Size	: <u>600 mm x 600 mm</u>
Panel thickness	: <u>34 mm</u>
Core	: <u>Inert cementitious fill</u>
Casing	: <u>Die-formed corrosion resistant painted steel</u>
Performance	: <u>MOB PF2 PS/SPU MEDIUM GRADE</u>
Point load (25 mm Sq)	: <u>3.0 kN</u>
Point load (300 mm Sq)	: <u>4.5 kN</u>
U.D.L.	: <u>8.0 kN per m²</u>

Above working loads required to impose 2.4 mm deflection.
Working loads stated have a safety factor of 3.

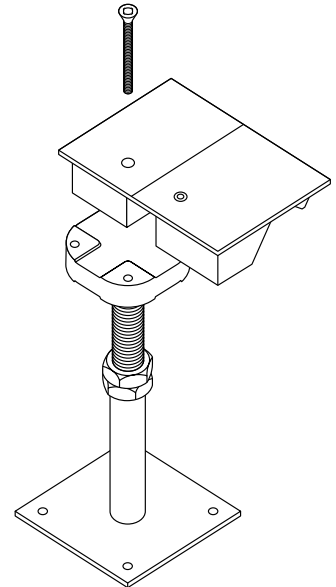

Application

Exceptional strength and resistance to deformation make this an ideal option for general office areas where high traffic and heavy rolling loads are expected.

Installation

Pedestals are adhered to the concrete sub floor using a specially formulated 2 part epoxy adhesive. Where applicable, apply a coat of floor sealer to ensure a good dust free bond between pedestal and sub floor. A provision for mechanical fixing is built into all pedestal base plates.

Void depths

Depths can vary from a minimum of 50 mm up to 1200 mm (including stringers).

Electrical performance

Earth bonding of the system is achieved by means of bonding conductor clips in the gasket. Main bonding conductors can be fixed to the pedestal bases for connection to the building earth. Service boxes can be factory fitted, along with outlet grommets to pass cables through the floor void.

Weight

System weight with finish floor height (FFH) of 300 mm and without stringers and panel coverings is 42.5 kg/m² approx.

Humidity

DSF2 is suitable for conditions up to 90% RH at 30°C.

Fire

DSF2 satisfies the MOB PF2 PS/SPU small scale fire test. Steel surfaces Class 0 to BS 476 pt 6; surface spread of flame Class 1 to BS 476 pt 7.

Accessories

A wide range of accessories allows you to create custom-made designs for virtually all requirements and ensure compatibility with air distribution and wiring systems. For details of air grilles, floor coverings, stringers, steps, ramps and expansion joints, contact your local USG sales representative.

United Kingdom

USG (UK) Ltd
1 Swan Road
South West Industrial Estate
Peterlee
Co. Durham SR8 2HS
Tel: +44 (0)191 586 1121
Fax: +44 (0)191 586 0097

Middle East

USG Middle East Ltd.
P.O. Box 2897
Dammam 31461
Saudi Arabia
Tel: +966 3 842 5052/843 4225
Fax: +966 3 842 49 82

USG Middle East Trading Ltd.
P.O. Box 26895
Dubai
U.A.E.
Tel: +971 4 550 651/550 652
Fax: +971 4 550 656

Eastern Europe

USG Interiors East GmbH
Von Siemens Strasse 2
D-48291 Telgte
Germany
Tel: +49 (0)2504 93110
Fax: +49 (0)2504 931166

Scandinavia

Donn Scandinavia
Sjöängsvägen 7
192 72 Sollentuna
Sweden
Tel: +46 (0) 8754 93 60
Fax: +46 (0) 8626 94 51

